

Mounting flange - HC-B-AF - 1686533

Please be informed that the data shown in this PDF Document is generated from our Online Catalog. Please find the complete data in the user's documentation. Our General Terms of Use for Downloads are valid (<http://phoenixcontact.com/download>)



Panel mounting flange for HEAVYCON-ADVANCE TMS housing with screw locking



Key Commercial Data

Packing unit	20 pc
GTIN	 4 017918 194345
GTIN	4017918194345

Technical data

Dimensions

Width	42 mm
Height	20.5 mm

Ambient conditions

Ambient temperature (operation)	-40 °C ... 125 °C
---------------------------------	-------------------

General

Note	2 for every connector
Pg screw connection	none
Material	Aluminum, die-cast
Note	2 for every connector
Assembly instructions	In order to guarantee that the ground conductor contact functions even when plugged in at an angle, the two panel mounting flanges must have sufficient electrical contact with the metal mounting panel.
Connection	Minimum panel thickness of a steel sheet: 2.0 mm. For mounting with self-tapping M4 screws: 3.6 mm drill-hole diameter

Environmental Product Compliance

China RoHS	Environmentally friendly use period: unlimited = EFUP-e
------------	---

Mounting flange - HC-B-AF - 1686533

Technical data

Environmental Product Compliance

	No hazardous substances above threshold values
--	--

Drawings

Dimensional drawing

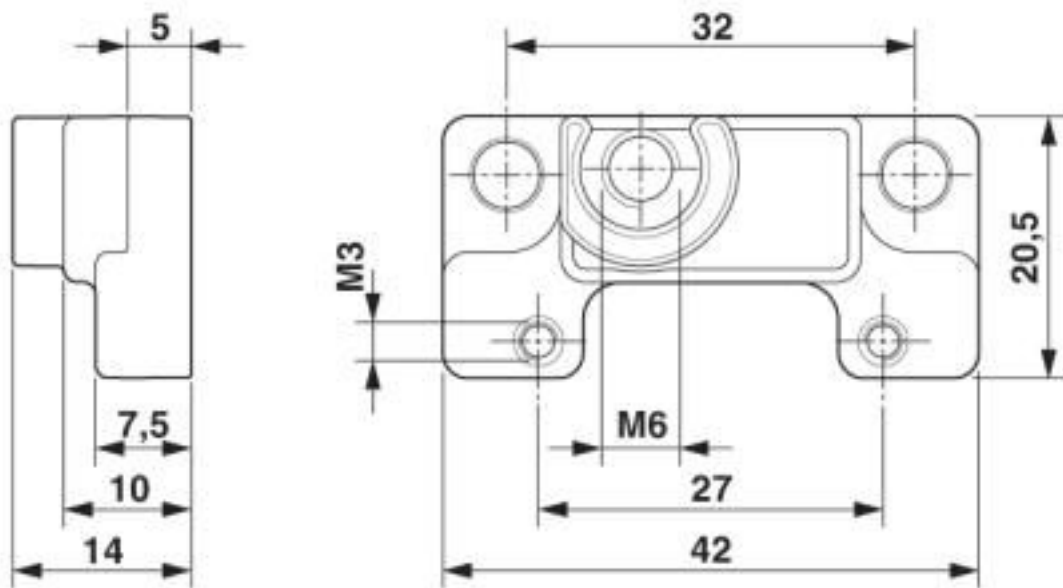

Dimensional drawing

Classifications

eCl@ss

eCl@ss 10.0.1	27440192
eCl@ss 11.0	27440192
eCl@ss 4.0	27140800
eCl@ss 4.1	27140800
eCl@ss 5.0	27189200
eCl@ss 5.1	27189200
eCl@ss 6.0	27261200
eCl@ss 7.0	27440210
eCl@ss 8.0	27440210
eCl@ss 9.0	27440192

ETIM

ETIM 2.0	EC000007
ETIM 3.0	EC000007
ETIM 4.0	EC000007

Mounting flange - HC-B-AF - 1686533

Classifications

ETIM

ETIM 5.0	EC002310
ETIM 6.0	EC002310
ETIM 7.0	EC002310

UNSPSC

UNSPSC 6.01	31261501
UNSPSC 7.0901	31261501
UNSPSC 11	31261501
UNSPSC 12.01	31261501
UNSPSC 13.2	39121421
UNSPSC 18.0	39121421
UNSPSC 19.0	39121421
UNSPSC 20.0	39121421
UNSPSC 21.0	39121421

Approvals

Approvals

Approvals

EAC

Ex Approvals

Approval details

EAC		RU C- DE.AI30.B.01102
-----	---	--------------------------

Phoenix Contact 2020 © - all rights reserved
<http://www.phoenixcontact.com>

PHOENIX CONTACT GmbH & Co. KG
Flachsmarktstr. 8
32825 Blomberg
Germany
Tel. +49 5235 300
Fax +49 5235 3 41200
<http://www.phoenixcontact.com>