

Housing - HC-EVO-D25-SLWS-2SSM20-PLR-BK - 1421466

Please be informed that the data shown in this PDF Document is generated from our Online Catalog. Please find the complete data in the user's documentation. Our General Terms of Use for Downloads are valid (<http://phoenixcontact.com/download>)



Box mounting bases D25, with single locking latch, material: PA, cable outlets: 2, lateral, height: 57 mm, cable gland: none, support sleeve: no, 2x M20, Standard, including 2x reducing adapter

Your advantages

- ✓ Flexible cable outlet direction, lateral or straight
- ✓ Lower costs than metal version
- ✓ Labeling option using 9 x 20 mm marking label
- ✓ Low weight
- ✓ Lower risk of condensation
- ✓ Both contact insert PE sheets are connected by means of a metal frame integrated in the sleeve housing
- ✓ Metal inlays ensure leading PE contact with angled plugs
- ✓ Completely corrosion-resistant
- ✓ Halogen-free plastic



Key Commercial Data

Packing unit	1 pc
GTIN	 4 055626 265087
GTIN	4055626265087

Technical data

Dimensions

Height	57 mm
Width	51 mm
Length	96.5 mm

Ambient conditions

Degree of protection (IP)	IP66
Degree of protection (NEMA)	12 (UL 50e)
Ambient temperature (operation)	-40 °C ... 125 °C

Housing - HC-EVO-D25-SLWS-2SSM20-PLR-BK - 1421466

Technical data

General

Note	For contact inserts HC-D25, A16
Size	D25
Housing type	Box mounting bases
Color	black
Locking type	with single locking latch
No. of cable outlets	2
Cable outlet	lateral
Screw connection	none
Type of the screw connection	2x M20
Housing material	PA
Material lock	PA
Flammability rating according to UL 94	V0 (Housing) V0 (Interlock)
Assembly instructions	Two M25 to M20 reducing adapters are included
Connection	One of the two openings for the screw connections is sealed but can be broken open using a screwdriver.

Environmental Product Compliance

China RoHS	Environmentally Friendly Use Period = 50 years
	For details about hazardous substances go to tab "Downloads", Category "Manufacturer's declaration"

Drawings

Dimensional drawing

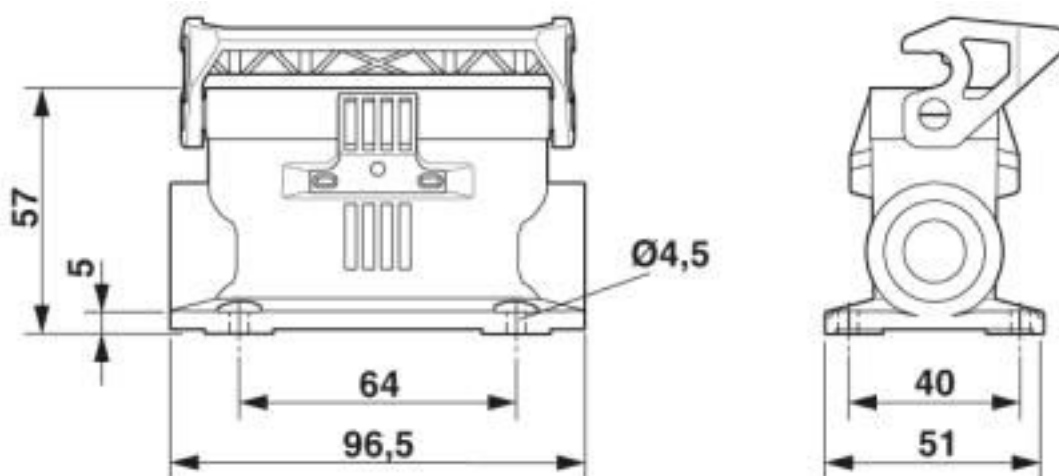

Dimensional drawing

Housing - HC-EVO-D25-SLWS-2SSM20-PLR-BK - 1421466

Classifications

eCl@ss

eCl@ss 10.0.1	27440202
eCl@ss 11.0	27440202
eCl@ss 5.1	27261200
eCl@ss 6.0	27261200
eCl@ss 7.0	27440202
eCl@ss 8.0	27440202
eCl@ss 9.0	27440202

ETIM

ETIM 5.0	EC000437
ETIM 6.0	EC000437
ETIM 7.0	EC000437

Approvals

Approvals

Approvals

EAC / DNV GL

Ex Approvals

Approval details

EAC		RU C- DE.AI30.B.01102
-----	--	--------------------------

DNV GL		https://approvalfinder.dnvgl.com/	TAE000037S
--------	--	---	------------

Accessories

Accessories

Full screw connection

Housing - HC-EVO-D25-SLWS-2SSM20-PLR-BK - 1421466

Accessories

Cable gland - G-INS-M20-S68N-PNES-BK - 1411133



Cable gland, cable gland material: PA, external cable diameter 6 mm ... 12 mm, shielding: no, connecting thread: M20 x 1.5, color: jet black RAL 9005

Housing latches

Housing brackets - HC-D25-SL-PLBK - 1414668



Replacement plastic single locking latch, for HC-EVO-D25.....BK housing

Plug for cable screw gland

Screw plug - A-INSP-M20-65N-P-BK - 1415206



Screw plug, material: PA, connecting thread: M20 x 1.5, color: jet black RAL 9005, with O-ring

Protective cover

Protective covers - HC-STA-D25-BCSFS-PLR-BK - 1424401



Protective cover D25, for single locking latch, protective cover material: PA, height: 19 mm

Reducing adapter

Reducing adapter - REDUC-K-KV-M25/M20 BK - 1411232



Reducing adapter, material: Polyamide fiberglass reinforced, connecting thread: M25 x 1.5, color: black, with flat gasket

Phoenix Contact 2020 © - all rights reserved
<http://www.phoenixcontact.com>

PHOENIX CONTACT GmbH & Co. KG
Flachsmarktstr. 8
32825 Blomberg
Germany
Tel. +49 5235 300
Fax +49 5235 3 41200
<http://www.phoenixcontact.com>