

Philips screwdriver - SF-PZSL 1-80 S-VDE - 1212699

Please be informed that the data shown in this PDF Document is generated from our Online Catalog. Please find the complete data in the user's documentation. Our General Terms of Use for Downloads are valid (<http://phoenixcontact.com/download>)



Screwdriver, Plus-Minus PZH slot, VDE-isolated, size: PZ 1 x 80, two component handle, with non-slip grip

Your advantages

- VDE approval
- Screwdrivers for Phillips screws with Pozidriv and Phillips Recess screw head

Key Commercial Data

Packing unit	10 pc
GTIN	 4 046356 716628
GTIN	4046356716628

Technical data

Dimensions

Length (b)	178 mm
Width (a)	33 mm
Blade width	3 mm
Blade height	80 mm
Wrench size	0 mm

General

Type	Phillips
Material	alloyed tool steel

Environmental Product Compliance

California Proposition 65	Further information on California's prop. 65 is available under "Downloads" in the manufacturer's declaration
---------------------------	---

Drawings

Philips screwdriver - SF-PZSL 1-80 S-VDE - 1212699

Pictogram



Dimensional drawing

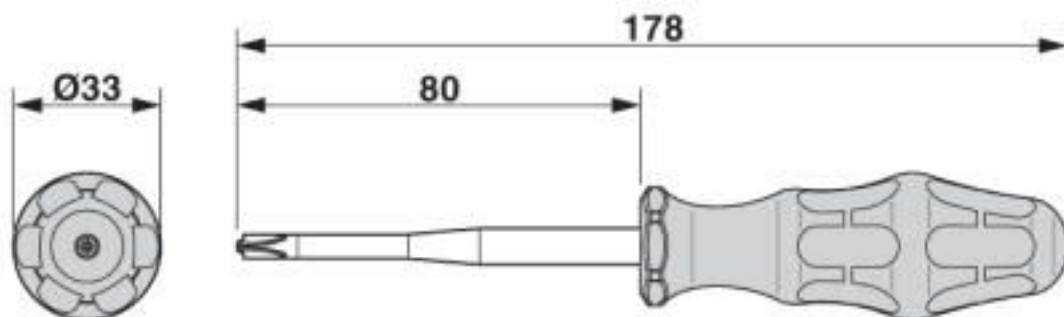

Philips screwdriver - SF-PZSL 1-80 S-VDE - 1212699

Classifications

eCl@ss

eCl@ss 10.0.1	21040406
eCl@ss 11.0	21040406
eCl@ss 4.0	21040400
eCl@ss 4.1	21040400
eCl@ss 5.0	21040400
eCl@ss 5.1	21040400
eCl@ss 6.0	21040400
eCl@ss 7.0	21040406
eCl@ss 8.0	21040406
eCl@ss 9.0	21040406

ETIM

ETIM 3.0	EC000158
ETIM 4.0	EC000144
ETIM 5.0	EC000144
ETIM 6.0	EC000144
ETIM 7.0	EC000144

UNSPSC

UNSPSC 6.01	27111701
UNSPSC 7.0901	27111701
UNSPSC 11	27111701
UNSPSC 12.01	27111701
UNSPSC 13.2	27111701
UNSPSC 18.0	27111701
UNSPSC 19.0	27111701
UNSPSC 20.0	27111701
UNSPSC 21.0	27111701

Approvals

Approvals

Approvals

VDE Zeichengenehmigung / EAC

Ex Approvals

Approval details

Philips screwdriver - SF-PZSL 1-80 S-VDE - 1212699

Approvals

VDE Zeichengenehmigung		http://www2.vde.com/de/Institut/Online-Service/VDE-gepruefteProdukte/Seiten/Online-Suche.aspx	40032921
------------------------	---	---	----------

EAC			RU C- DE.AI30.B.01750
-----	---	--	--------------------------

Phoenix Contact 2020 © - all rights reserved
<http://www.phoenixcontact.com>

PHOENIX CONTACT GmbH & Co. KG
Flachmarktstr. 8
32825 Blomberg
Germany
Tel. +49 5235 300
Fax +49 5235 3 41200
<http://www.phoenixcontact.com>